

# Atlas Copco

## Oil-injected Rotary Screw Compressors



**GA 15-22**  
15-22 kW/20-30 hp



*Atlas Copco*



## Total capability, total responsibility

Right at the heart of your business, Atlas Copco delivers quality compressed air for superior operational capacity. From compressed air generation to point of use, you can choose from our wide range of products to create a complete compressed air system tailored to your specific needs. All Atlas Copco products are engineered to integrate seamlessly, ensuring the highest level of reliability and energy efficiency. As a result, Atlas Copco can take full responsibility for your compressed air infrastructure with a guarantee of best-in-class quality. With a global presence in over 150 countries, we can provide an unrivalled service to maintain and continually improve your compressed air system performance.

Backed by 100 years at the forefront of compressed air, Atlas Copco products offer the finest quality and efficiency. Our goal is to be First in Mind—First in Choice®. That is why Atlas Copco's pursuit of innovation never ceases, driven by the dedication to meet and exceed your demands. Always working with you, we are committed to providing the customized air solution that is the driving force behind your business.

***Atlas Copco:  
Customized Quality Air Solutions through  
Innovation, Interaction and Commitment.***

First in Mind—First in Choice®

# Built to last

Integrated onto the production floor, Atlas Copco's GA provides a dependable flow of compressed air directly to the point of use. No need for a separate compressor room or an elaborate and

costly piping system. Built to perform with the highest efficiency, the GA keeps your production running smoothly and reliably.



## ASSURED RELIABILITY

Atlas Copco's GA compressors are engineered, manufactured and tested in accordance with ISO 9001, ISO 14001 and ISO 1217,

Ed. 3, Annex C. Even in harsh working conditions, the GA takes reliability to a new level.

## THE LATEST ELEMENT TECHNOLOGY

Atlas Copco is committed to developing the most efficient screw element for each GA generation. Developed from extensive R&D by dedicated Atlas Copco engineers, the latest version of the patented oil-injected rotary screw element provides unrivalled efficiency. The production of Atlas Copco screw elements is controlled by six sigma quality standards. On top of that, every single compressor is tested and qualified before it leaves the factory, guaranteeing absolute peace of mind.

## A TIME-PROVEN DRIVE SYSTEM

The most efficient screw elements are driven by a time-proven direct drive system and powered by totally enclosed, high efficiency motors. For many years GA's have been equipped with efficiency 1 – EPACT motors giving our customers the advantage of low power consumption.

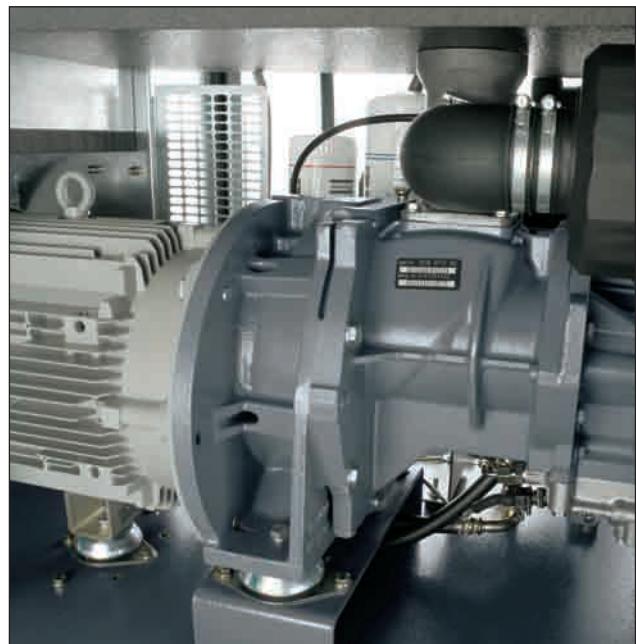



# Superior performance and reliability

Set to meet your specific requirements and tackle your daily challenges, Atlas Copco offers you the GA, by far the most reliable tank-mounted workshop solution. Immediately ready to supply high quality air, this powerful solution provides you with the exceptional reliability, efficiency and integration you are looking for.

## GA 15 – GA 18 – GA 22

### RELIABLE WORKSHOP SOLUTION

- High performance beating any workshop solution.
- Complete solution mounted on a tank and ready to supply high quality air immediately after delivery.
- Controls tailored to the needs of any workshop: the Elektronikon® I regulator is easy to comprehend and operate by anyone in the workshop using simple universal pictograms.



1 Compressor Element

2 Axial Fan

3 Coolers

4 Oil Separator

5 Elektronikon I

6 Air Inlet Filter

7 Motor

8 Oil Filter



# Protecting your production

Untreated compressed air contains moisture, aerosols and dirt particles that can damage your air system and contaminate your end product. Resulting maintenance costs can far exceed air treatment costs. We believe in effective prevention.



## INCREASE YOUR PRODUCTION RELIABILITY

Low quality air heightens the risk of corrosion in your system, which can lower the life span of your air tools and production equipment. The GA's filtration process produces clean air that enhances your system's reliability, avoiding costly downtime and production delays.



## SAFEGUARD YOUR PRODUCT QUALITY

Compressed air coming into contact with your final products should not affect their quality. The GA provides the clean, dry air that will protect your product's reputation in the marketplace.



## REDUCE YOUR ENERGY COSTS

Clean, treated air reduces the risk of corrosion and leaks in your compressed air system. A 3 mm leak could easily add up to €1800 to your energy bill annually.



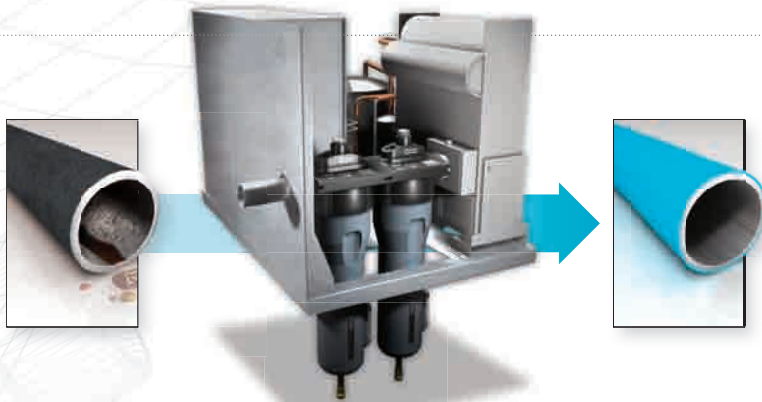

## PROTECT THE ENVIRONMENT

With leaks and energy waste minimized and the unsafe disposal of untreated condensate eliminated, you can safeguard the environment and comply with stringent international regulations.



## INTEGRATED PURITY

The filters and integrated refrigerant-type air dryer (IFD) efficiently remove moisture, aerosols and dirt particles to protect your investment. This quality air expands the life of equipment, increasing efficiency and ensuring quality in your final product.

CONFIGURE YOUR GA FOR THE AIR QUALITY YOU NEED	ISO QUALITY CLASS	DIRT PARTICLE SIZE	WATER PRESSURE DEW POINT	OIL CONCENTRATION
GA WorkPlace	3.-.4	3 microns	-	3 ppm
 GA WorkPlace FF with IFD	3.4.4	3 microns	+5°C, 41°F	3 ppm
 GA WorkPlace FF with IFD & Class 2 integrated filter	2.4.2	1 micron	+5°C, 41°F	0.1 ppm
 GA WorkPlace FF with IFD & Class 1 integrated filters	1.4.1	0.01 microns	+5°C, 41°F	0.01 ppm



# Peace of mind



With the GA, Atlas Copco does not just offer the most reliable and efficient compressors. From filter kits to a complete piping installation, Atlas Copco can take responsibility of your entire compressed air system to provide you with best-in-class air. Choose from a wide range of Atlas Copco after sales products and services that will have your GA performing at its best for years to come. Qualified Atlas Copco support is available in over 150 countries.

*Providing easy access to all components, the GA is built to facilitate maintenance.*



## GENUINE PARTS & LUBRICANTS

Don't compromise your investment in quality by buying parts that are not manufactured according to Atlas Copco's standards of excellence. Only Atlas Copco genuine parts can deliver our well-known quality, durability, and low energy and oil consumption. Atlas Copco lubricants ensure that your GA continues to run smoothly.

## SERVICEPLAN

Choose a Total Responsibility, Preventative Maintenance or Inspection Plan to get the scheduled maintenance to keep your compressor operating trouble free. Rest assured that Atlas Copco can offer its 24/7 backup to keep your production running.

## AIRMONITOR

Monitor the performance of your GA at any time from your desk, or let your local Atlas Copco center do it for you. With AIRmonitor™, you check your compressed air system online, immediately receiving warning indications and even remotely taking preventive action to avoid downtime.

## AIRNET

Expect the highest efficiency from your GA, and the piping built around it. AIRnet™ safely delivers high-quality compressed air from point of generation to point of use. Separate workplaces are effortlessly connected. Fixed to walls or ceilings, AIRnet's range of fittings lets you custom-build a compressed air system specific to your production needs.



# Options

		GA 15 – GA 18 – GA 22
AIR TREATMENT	Integrated filter kit class 1*	•
	Integrated filter kit class 2*	•
	Dryer bypass*	•
CONDENSATE TREATMENT	Electronic water drain (EWD) on coolers	•
	Air receiver drain (EWD or timer drain)	•
PROTECTION	Motor space heater	•
	Phase sequence relay	•
	Tropical thermostat	•
	Freeze protection	•
PUBLIC WORKS	Main power isolator switch	•
OILS	Food grade oil	•
	Roto – Xtend duty oil	•
GENERAL OPTIONS	Special canopy color	•
	SQL air receiver	•

\* FF units only.

# Technical specifications

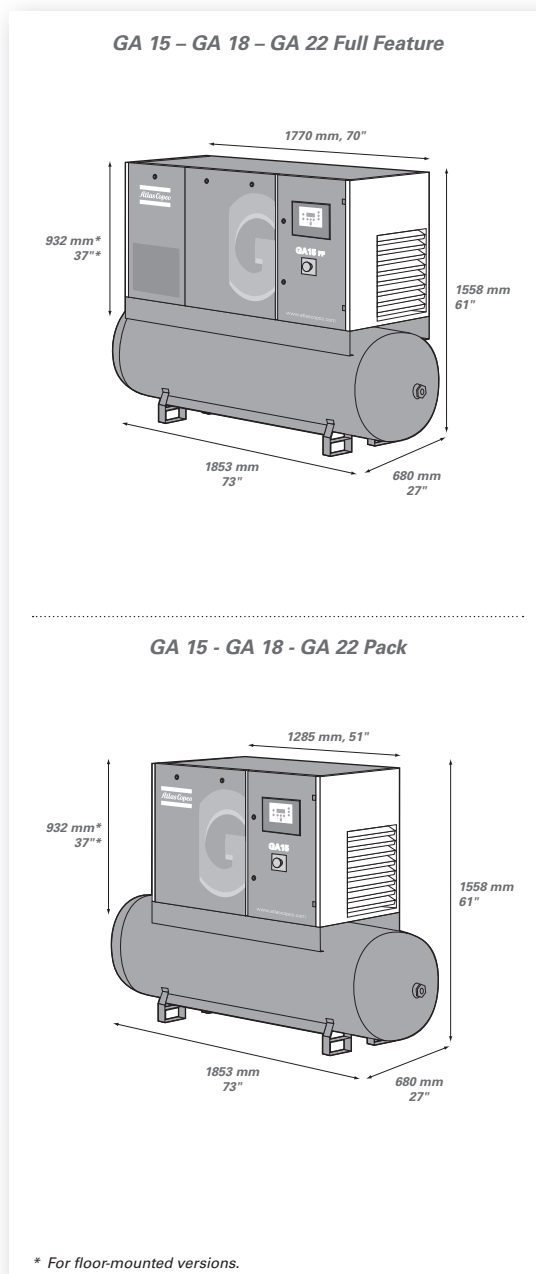

COMPRESSOR TYPE	Max. working pressure	Capacity FAD*	Installed motor power	Noise level**	Weight	
	WorkPlace/WorkPlace FF					WorkPlace/WorkPlace FF
<b>50 Hz VERSION</b>						
	bar(e)	m <sup>3</sup> /h	kW	dB(A)	kg	
GA 15	7.5	7.5/7.3	154.8	15	72	375/440
	8.5	8.5/8.3	141.8	15	72	375/440
	10	10/9.8	130.7	15	72	375/440
	13	13/12.8	108.4	15	72	375/440
GA 18	7.5	7.5/7.3	189	18.5	73	395/470
	8.5	8.5/8.3	180.7	18.5	73	395/470
	10	10/9.8	156.6	18.5	73	395/470
	13	13/12.8	133.9	18.5	73	395/470
GA 22	7.5	7.5/7.3	216.7	22	74	410/485
	8.5	8.5/8.3	209.9	22	74	410/485
	10	10/9.8	186.1	22	74	410/485
	13	13/12.8	162	22	74	410/485
<b>60 Hz VERSION</b>						
	psig	cfm	hp	dB(A)	lbs	
GA 15	100	107/104	90.1	20	72	827/970
	125	132/128	83.9	20	72	827/970
	150	157/149	75.9	20	72	827/970
	175	181/178	62.1	20	72	827/970
GA 18	100	107/104	108.7	25	73	871/1036
	125	132/128	101.1	25	73	871/1036
	150	157/149	91.7	25	73	871/1036
	175	181/178	80.1	25	73	871/1036
GA 22	100	107/104	128.4	30	74	904/1069
	125	132/128	118.7	30	74	904/1069
	150	157/149	107.4	30	74	904/1069
	175	181/178	98.5	30	74	904/1069

\* Unit performance measured according to ISO 1217, Ed. 3, Annex C-1996.

\*\* Mean noise level measured according to ISO 2151/Pneuro/Cagi PN8NTC2 test code; tolerance 2 dB(A).

### Reference conditions:

- Absolute inlet pressure 1 bar (14.5 psi)
- Intake air temperature 20°C, 68°F

### FAD is measured at the following working pressures:

- 7.5 bar versions at 7 bar
- 8.5 bar versions at 8 bar
- 10 bar versions at 9.5 bar
- 13 bar versions at 12.5 bar

Pressure dew point of integrated refrigerant dryer of GA 15 – GA 18 – GA 22 at reference conditions 5°C, 37°F.

Air receiver size: 500 L.  
Added weight: 125 kg.



In order to be First in Mind—First in Choice® for all your compressed air needs, Atlas Copco delivers the products and services that help increase your business' efficiency and profitability.

Atlas Copco's pursuit of innovation never ceases, driven by your need for reliability and efficiency. Always working with you, we are committed to providing you the customized quality air solution that is the driving force behind your business.



**Never use compressed air as breathing air without prior purification in accordance with local legislation and standards.**



[www.atlascopco.com](http://www.atlascopco.com)